



NSW DEPARTMENT OF
PRIMARY INDUSTRIES

This document is part of a larger publication and is subject to the disclaimers and copyright of the full version from which it was extracted.

The remaining parts and full version of the publication, as well as updates and copyright and other legal information can be found at:

<http://www.dpi.nsw.gov.au/agriculture/field/pastures/silage/successful-silage>

Feed testing: assessing silage quality

12.0	Introduction	312
12.1	Testing the parent forage	313
12.2	Collecting silage samples	315
12.3	Subjective appraisal of silage in the field	318
12.4	Using and interpreting silage quality analyses	319
12.5	Appendices	333

Feed testing: assessing silage quality

In this chapter

12.0 Introduction	312
12.1 Testing the parent forage	313
12.2 Collecting silage samples	315
12.2.1 Corers	315
12.2.2 Collecting a representative sample	316
12.2.3 Sample storage, packaging and delivery to the laboratory	317
12.3 Subjective appraisal of silage in the field	318
12.4 Using and interpreting silage quality analyses	319
12.4.1 Silage DM content	321
12.4.2 Energy value and digestibility	323
12.4.3 Fibre analyses	326
12.4.4 Protein analyses	328
12.4.5 Silage fermentation quality	331
12.5 Appendices	333
12.A1 Composition of Australian hays and silages	333
12.A2 Interpreting feed analysis results for problem silages	334

The authors

A.G. Kaiser and
J.W. Piltz

*Department of Primary
Industries, Wagga Wagga
Agricultural Institute, Wagga
Wagga, NSW*

The Key Issues

- Feed testing is an essential tool in a feeding program, providing important information on the nutritive value of silages.
- The success of a silage-making operation can be assessed by monitoring quality changes during the ensiling process. This can be achieved by comparing the parent forage and the resulting silage.
- Sampling procedure is critical. It is important to obtain a representative sample of the silage and ensure that it does not deteriorate during transport to the laboratory.
- A preliminary, but subjective, evaluation of silage quality can be made in the field by assessing silage colour and aroma. This should be followed up with a laboratory test.
- The laboratory test should include DM content, digestibility or ME content, crude protein content and silage fermentation quality. Ammonia-N content and silage pH can be used as a guide to silage fermentation quality.
- Silages are fermented feeds and contain volatile compounds that are lost if the sample is dried for analysis. This will affect the results. Check whether your feed-testing laboratory has taken this into account when calculating the results.

Section 12.0

Introduction

Feed testing is an integral part of a well-managed forage conservation program. It establishes the quality of a silage and the success of the ensiling process, and can be a useful way to determine if quality and wilting targets have been met.

‘Quality’ – encompassing all the attributes that influence a silage’s nutritive value – determines the potential animal production per tonne of silage and so is an important indicator of whether producing the silage has been profitable.

Perhaps the most important use of feed tests is in the formulation of diets. The ME and crude protein content of a silage determine whether it will supply adequate nutrients for animal production. The feed test provides information that can be used to answer key feed management questions:

- ▶ Is the silage suitable for the intended animal production target?
- ▶ What production response can be expected?
- ▶ If used as a component of a diet, how much silage will need to be fed?
- ▶ Will other supplements be required? If so, what quantity?

An early feed test, well before the silage is to be used, can provide valuable information to assist with budgeting and formulation of diets.

If the feed test indicates that the silage quality is below the level required for the animal production targets, there is time to source alternative supplements.

The results of feed tests may be used as an objective basis for costing silage, for trading crops and pastures for silage production, and for trading silage.

The trading of baled silage is becoming more popular. Hay prices are often used as a reference point, with adjustments for differences in DM content, possible differences in quality and conservation costs.

Information on the nutritive value of Australian hays and silages (see Appendix 12.A1) shows that silages, on average, have a higher crude protein and ME content than hays in each forage class. The large range in crude protein, DM digestibilities and ME values for the silages highlight the potential quality many producers are losing due to poor silage-making practices. The hay data indicates a similar situation with hay-making practices.

Section 12.1

Testing the parent forage

The quality of the parent forage is a key factor influencing the quality of the resulting silage. Testing the parent forage will provide a guide to the *potential* quality of the silage.

In a well-managed system, where losses are low, the silage DM content, digestibility and ME content will be similar or slightly lower, and crude protein content similar or slightly higher, than that in the parent forage.

However, if there have been significant quality losses during wilting, harvesting or storage, the parent forage will no longer accurately indicate silage quality. There can be quite significant reductions in digestibility (and ME content) and crude protein content. In cases of overheating or poor silage fermentation, the availability of crude protein may also be reduced.

Researchers and some producers monitor the quality losses during various stages of the ensiling process to identify problem areas that need to be targeted with improved management.

The time of sampling is important; it determines which categories of loss contribute to any differences between parent forage and silage ME content (see Figure 12.1).

Obtaining a complete inventory of where quality losses occur may only be realistic in research programs. However, producers who have had difficulties producing higher-quality silage may find it useful to compare the quality of the parent forage with that of the resulting silage to help diagnose the problem. The best time to sample the parent forage is at mowing. Samples at a later stage will not account for all the losses that can occur during the ensiling process (see Figure 12.1).

Figure 12.1

Using feed tests to track changes in quality during the silage-making process.

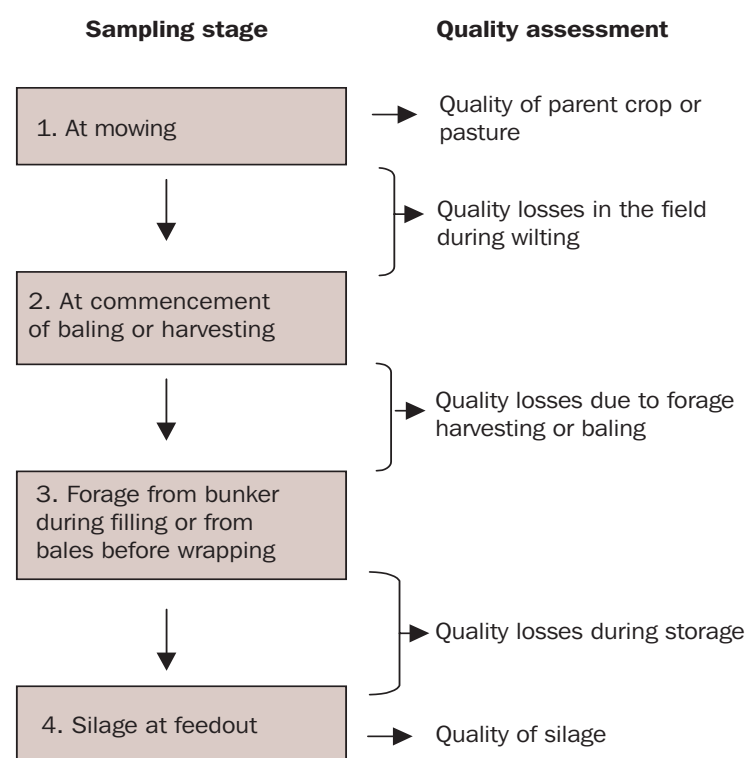

*Note: This sampling regime (representative samples are essential at each stage) uses laboratory tests to monitor changes in forage/silage **quality**. There will also be losses in the **quantity** of forage (DM losses) during various stages of the ensiling process (see Chapter 2). These losses are usually only determined in research studies and are difficult to determine under farm conditions.*

Diagnosing quality problems

Diagnosing quality problems using feed test analyses of parent forage and the resulting silage

- If the ME content of the parent forage is low, the crop or pasture has been cut too late.
- If the ME content of the parent forage is considerably higher (>0.5 MJ/kg DM) than the silage, there have been significant losses during silage making or storage (see Chapters 2, 6, 8 and 9).
- If parent forage and silage ME content are similar, conservation losses have been minimal.
- The silage ME cannot be significantly higher than the parent forage ME. Such a result indicates a technical problem – a laboratory error or, more likely, a sampling problem.

The sampling method is important if a representative sample of parent forage is to be collected. When sampling mown forage in the paddock, a series of small 'grab' samples (minimum of 12) should be collected across the whole paddock. Each 'grab' should sample the full depth of the swath or windrow.

As soon as sampling has been completed, bulk and *thoroughly mix* the sample. Make sure the mixing surface is clean to avoid contamination. If you have collected more forage than the laboratory requires, take a sub-sample by splitting the sample two or four ways and retaining a half or a quarter. The method for sampling wilted forage before baling is the same as for freshly mown material.

If sampling forage that is to be chopped by a forage harvester, a representative sample can be collected either from the windrow at mowing or prior to harvest, or from several loads as they are delivered to the pit or bunker. Note the difference that the stage where the samples are collected has on interpretation of quality changes (see Figure 12.1).

Each forage-harvested sample collected over a day should be put into a plastic bag, sealed and kept in a refrigerator or insulated cooler (e.g. an Esky®) with freezer bricks. It is best not to use ice in the cooler in case water from the melting ice contaminates the sample. When all samples are collected they can then be bulked together, mixed and sub-sampled in a similar manner to that described earlier.

Once bulked, mixed and sub-sampled, place the sample for analysis in a plastic bag, squeeze to remove air, seal the bag immediately and store in a freezer. It is important to minimise the interval from sampling to freezing, as fresh forage samples deteriorate quickly. Plant sugars, for example, can be lost quickly via respiration (see Chapter 2, Section 2.2.1).

Once frozen, the sample will remain stable and can be forwarded to the feed testing laboratory. An overnight courier service is the most reliable means of getting the sample to the laboratory in good condition. The sample should be well wrapped in newspaper, to minimise thawing, and sent early in the week so that it can be received and processed before the next weekend. If the sample thaws, it can deteriorate.

Microwave drying is an alternative method of preparing parent forage samples (see Chapter 6, Section 6.4.2) and is advisable where an overnight courier service is not available for frozen samples. However, care should be taken to ensure the sample is not charred or heat damaged during the drying process.

12.2

Collecting silage samples

12.2.1

Corers

Core sampling tubes are the most acceptable tools for obtaining representative silage or hay samples. They are commercially available or can be made on-farm (see Figure 12.2).

A common construction material is stainless steel dairy air-line. This material is resistant to corrosion and the smooth surface creates little friction during sampling.

More sophisticated corers have a removable cutting head, but home-made corers simply rely on scalloping one end of the tube and sharpening with an angle grinder. It is important to keep the cutting surfaces sharp for efficient sampling.

Corers can be manually operated or fitted with an attachment for use with a power drill. With a manually operated corer, a hole is drilled through one end of the pipe so that a lever/handle can be inserted. If using an electric drill, a variable speed unit is preferable so that slow speeds can be used to reduce heating at the tip.

The silage core can be pushed out of the corer using a length of wooden dowel.

Figure 12.2

Construction of a silage corer that can be used either manually or with a power drill.

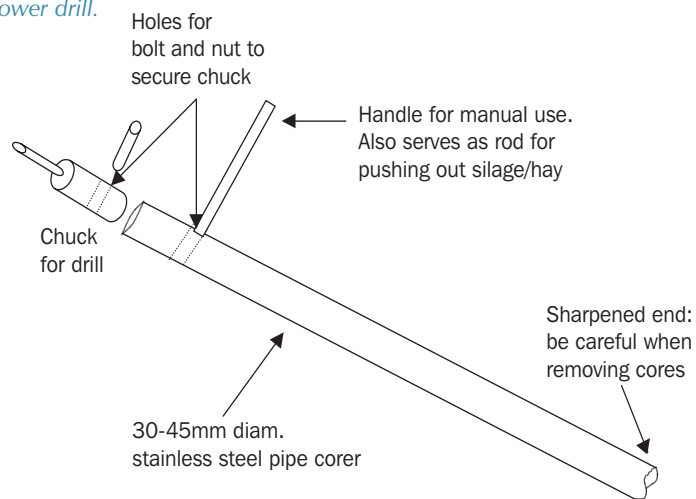

Source: F. Mickan

Plate 12.1

Using a corer like these is the most practical way of obtaining representative samples from bales of silage or hay.

Photograph: F. Mickan

12.2.2

Collecting a representative sample

Sampling technique can have an enormous effect on the value of silage feed test results. If it is not a representative sample, the results will not reflect the average composition of the silage ‘batch’ and can be misleading.

There can be considerable variation in the composition of silage within a pit or between bales produced from a single ‘batch’ of silage. The sample for feed testing must represent the average for the whole batch. Each batch should contain only forage mown and harvested from the same paddock, ideally within a 2-3 day period. Separate samples should be taken for each batch.

Silage sampling should be delayed for at least six and preferably 12 weeks to ensure that the fermentation is complete. The fermentation in a well-preserved silage is usually completed in less than six weeks. However, with less efficient preservation, the fermentation proceeds more slowly.

Sampling methods need to be varied according to the method of storage

Bunker or pit silage: During feeding, collect at least 12 samples across a freshly cut silage face (to avoid silage that has deteriorated due to prolonged exposure to air). A silage face represents only a small proportion of the silage in the bunker, so the value of test results from such samples will depend on how much variation in quality there is along the bunker or pit.

If bunkers are unopened, the plastic sheeting will need to be cut to collect a sample. Avoid places where rainwater collects on the sheet or near any holes. Samples, collected by using a corer or auger, should be taken from several locations along the length of the pit or stack to gain a representative sample. Avoid sampling from only the top 50 cm of the stack because this material may have been affected by exposure to air and may be of lower quality than the main body of silage.

Baled silage: Samples should be collected from a number of bales (at least 10-12) randomly selected from the total for that batch. The bales are cored from the middle of the curved surface of a round bale or from the end of a square bale. The corer should be taken through to the middle of the bale.

Tower silos: Tower silos are not common in Australia. Their design means sampling is only possible during feedout. To obtain a representative sample of the silage, daily samples need to be collected over the course of 7-10 days. These are frozen and then bulked for analysis.

Resealing bunkers, pits and bales after sampling

Plastic sheeting or plastic wrap should be resealed immediately, using commercially available tape or a patch especially designed for use with silage plastic.

Inferior plastic tapes, particularly those sensitive to UV light, should be avoided – they will deteriorate or fall off over time.

Make sure the silage plastic is clean and dry before applying a patch or tape.

Chapter 9, Section 9, gives more information on the correct use of silage tapes.

12.2.3

Sample storage, packaging and delivery to the laboratory

After collecting the samples, thoroughly mix the bulk sample, take a sub-sample of the quantity required, place it in a plastic bag, remove the air by squeezing the bag, and seal it immediately.

For added security, double seal the sample inside a second plastic bag. This is especially important if the silage contains stalky material, such as unchopped lucerne or cereals, which may puncture the plastic.

Never leave samples in vehicles, particularly on a hot day. They will deteriorate quickly if allowed to heat during storage and transport.

It is recommended that silage samples be frozen before sending to a feed testing laboratory. Frozen samples should be well wrapped in newspaper and packed in an insulated cooler containing a freezer brick during warm months. Testing laboratories may have guidelines on the best way to ensure samples arrive in good condition for analysis.

Important steps in collecting a silage sample

- Ensure that the sample is representative of the whole batch.
- When the sample is collected during storage, ensure that the bunker or bales are effectively resealed.
- Do not leave the sample in a vehicle – it will deteriorate if it is not sealed in a plastic bag and stored in a cool place (e.g. an insulated cooler) immediately.
- Freeze the sample as soon as possible.
- If poor sampling and handling procedures are used, the feed test results will be of little value.

Section 12.3

Subjective appraisal of silage in the field

While laboratory testing provides an objective assessment of silage quality, a preliminary appraisal can be made in the field using simple subjective criteria such as colour and aroma.

It must be stressed that observations based on colour and aroma are subjective, but they can provide useful support to a laboratory feed test when diagnosing problems. Tasting is not recommended as

poorly preserved silages may contain undesirable bacteria, yeasts and moulds, and it is unlikely to provide additional information beyond that provided by colour and aroma.

Mouldy or rotten silage indicates inadequate compaction or air penetration during storage, see Chapter 9, Section 9.8.2. and Appendices 9.A1 and 9.A2.

Colour	Silage characteristics and interpretation
Very dark olive green	Weather damaged and/or very wet silage with a poor fermentation. Usually occurs with high legume content or immature grass that may have been fertilised with a high rate of nitrogen. Sour or putrid aroma.
Dark olive green/brown	Normal colour for wilted legumes, which usually produce a darker-coloured silage than grasses.
Light green to green/brown	Normal colour range for grass, cereal and maize silages.
Pale green/straw yellow	Normal colour range for wilted grass silages. Tendency for heavily wilted silages with restricted fermentation to be greener.
Light amber brown	Typical colour for more mature grasses and cereals. Sometimes seen with low DM silages, and weather-damaged grass silages. Bottom layer of wet silage can be yellow with fruity or sour aroma.
Brown	Some heating has occurred during storage or due to aerobic spoilage during feedout. Some loss in digestibility and heat damage of protein. More common with wilted silages.
Dark brown	More extensive heating. May also be some black patches of silage on the surface. Significant loss in digestibility and high proportion of protein is heat damaged and unavailable to the animal. Due to inadequate compaction, delayed sealing or poor air exclusion. Usually accompanied by significant proportion of waste (mouldy) silage.
Aroma	Silage characteristics and interpretation
Mild, pleasantly acidic, sour milk or natural yogurt smell	Normal lactic acid fermentation – desirable.
Very little smell, but slightly sweet aroma	Heavily wilted silage with little fermentation, especially from crops with low sugar content. Stronger aroma as DM content falls.
Sweet, fruity alcoholic aroma	Yeasts have played an active role in the fermentation. Ethanol levels high. These silages are often unstable during feedout.
Sour vinegar smell	Poor fermentation dominated by bacteria producing acetic acid. Common with low DM, low-sugar forages. Intake likely to be depressed.
Rancid butter, putrid aroma	Poor fermentation dominated by clostridia bacteria that produce high levels of butyric acid. Silage wet and sometimes slimy. Rub silage between fingers, warm the hand for a few seconds and then smell. The presence of butyric acid is easily detected. Intake likely to be depressed. Not a common problem in Australia.
Strong tobacco or caramel smell with flavour of burnt sugar	Heat-damaged silage, dark brown in colour. Often palatable to stock but the nutritive value is very low.
Musty or mouldy aroma with only mild fermentation aroma	Mouldy silage due to poor compaction and sealing. Also evident in aerobically spoiled silage, which can be warm and have a compost aroma. Intake likely to be low; some silages may be rejected.

Section 12.4

Using and interpreting silage quality analyses

Silage differs from other ruminant feeds because it is a fermented product. The type of fermentation will influence silage quality, voluntary intake (and palatability), and the utilisation of the silage nitrogen by animals. As a result, the potential high level of animal production possible from a silage with a high ME and high protein content may not be realised if there has been a poor fermentation. Therefore, the conventional quality measures (digestibility and ME, and protein) used for other ruminant feeds are not sufficient for silage samples – some measure of *fermentation quality* is also needed. Ammonia-N and silage pH can be used as a guide to silage fermentation quality.

A sample feed analysis sheet for a silage, and guidelines on how to interpret these results, are given in Figure 12.3.

When interpreting laboratory feed test results the following points need to be considered:

1. The estimated digestibility and ME provided are usually predicted *in vivo* values (i.e. digestibility in the animal). Therefore, laboratories need standards of known digestibilities to calibrate their results.
2. Ideally, laboratories should indicate what methods they have used to estimate digestibility and ME.

Appendix 12.A2 provides examples of feed analysis results for problem silages.

Figure 12.3

How to interpret the information from a feed test.

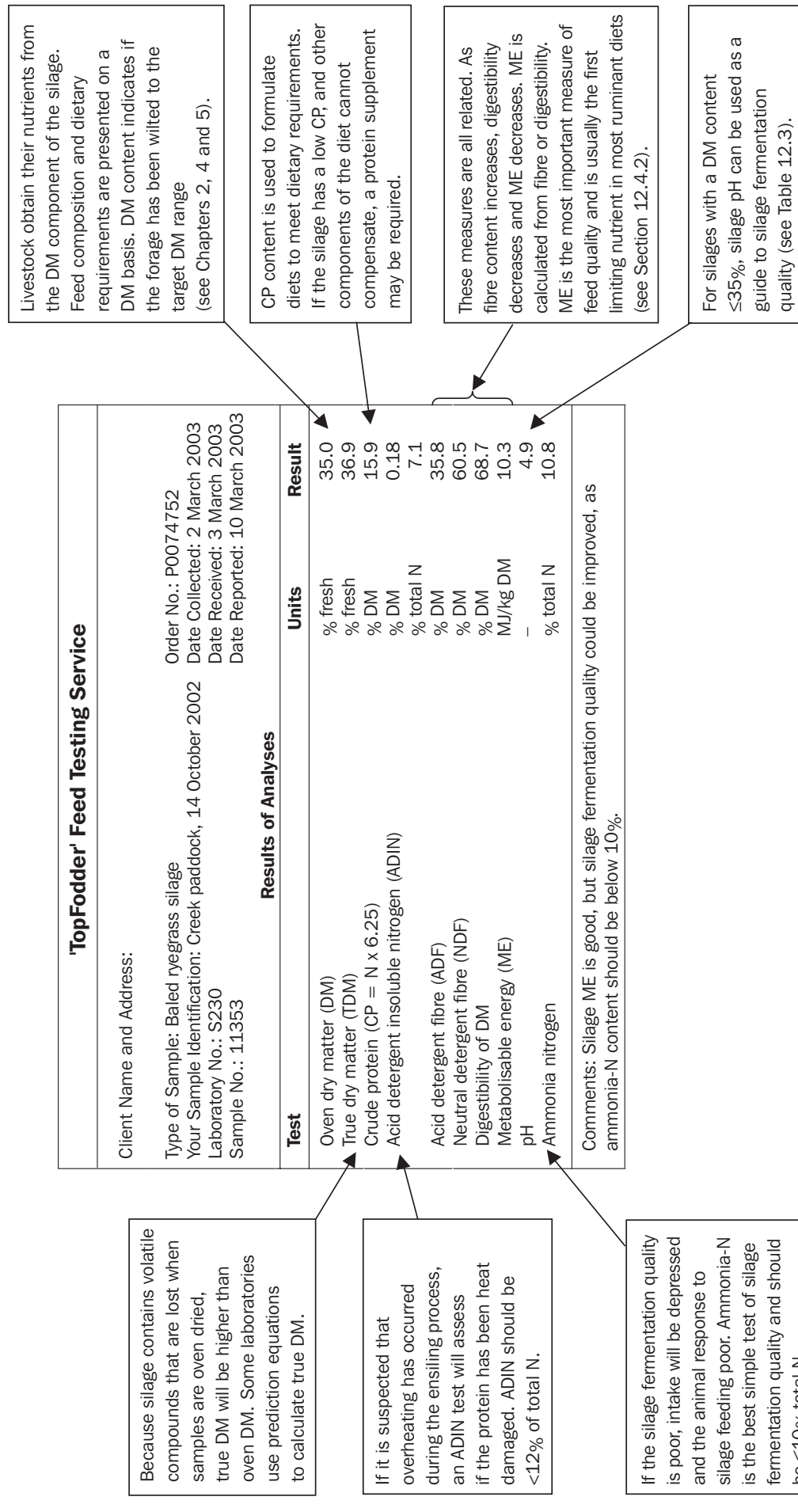

12.4.1

Silage DM content

Both DM and moisture content are used when describing the composition of a silage or its parent forage. Although one can easily be derived from the other, it does cause confusion (see Figure 12.4).

It is recommended that DM content (DM as a % of fresh weight) be used because:

- ▶ The costs of alternative feeds are compared on a DM basis and silages should be traded on a DM basis.
- ▶ Laboratories express the composition of feeds (e.g. crude protein and ME) on a DM basis.
- ▶ Diets for animals are formulated on a DM basis.

Knowing the DM content of a silage is important as it indicates the adequacy of wilting.

Forages ensiled below 30% DM will produce effluent, which can result in a significant loss of nutrients. These forages are also at risk of a poor fermentation, particularly if sugar levels are also low.

When forages are too dry (DM >50-55%) it is difficult to achieve anaerobic conditions and the silage will be more susceptible to heating and mould growth (see Chapter 2, Section 2.1.1).

The effect of volatile fermentation products on DM estimates

Because silage contains volatile fermentation products that are lost during conventional oven drying (volatile fatty acids, alcohols and some nitrogenous compounds), true DM content will be under-estimated. Lower DM silages usually undergo a more extensive fermentation and therefore contain more volatile products.

In the study illustrated in Figure 12.5, true DM content was determined by a method that directly measures water content. As DM content increases, the proportion of volatile products declines and the error due to volatile losses falls.

At an oven-dried DM content of 50% the error was only about one percentage unit (i.e. true DM content = 51%), indicating that there would be little difference between true DM and oven DM for oven DM levels >50%.

It is unlikely that commercial feed testing services will directly measure true DM content for silages. However, the prediction equation on the next page, based on the results in Figure 12.5, can be used to estimate true DM content from oven DM content, when samples are dried

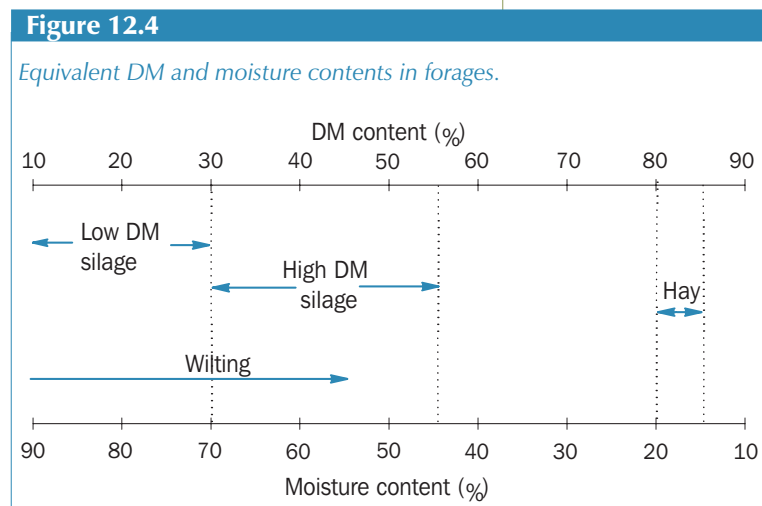
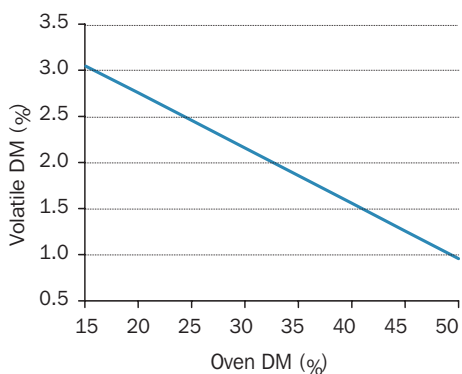

Figure 12.5

Loss of volatile compounds during the oven drying of silage samples (at 80°C).



Source: Kaiser et al. (1995) Note: oven DM + volatile DM = true DM.

Estimating True DM content

To estimate the true DM content of silage from an oven DM use the following prediction equation:

$$\text{True DM \%} = 3.96 + (0.94 \times \text{oven \% DM}) \quad (\text{Eqn 1})$$

Example:

If the oven DM of the silage = 33%

$$\text{True DM \%} = 3.96 + (0.94 \times 33) = 34.98\%$$

This equation should not be used with aerobically spoiled silages (see Chapter 2, Section 2.2.3, and Chapter 10, Section 10.2). The heating that occurs in these silages will drive off silage volatile compounds. As a result, there may be little difference between oven DM and true DM of aerobically spoiled silages.

As some feed testing laboratories in Australia may already be using this correction, check that the laboratory has not already made the correction before adjusting your results.

at 80°C. This equation is based on (and should only be used for) silages with oven DM in the range 15-50%. Further research is planned to increase the number, and range, of silages used to develop this calculation.

Failure to take account of the volatile losses during oven drying has important implications in a number of areas:

- ▶ Laboratory analyses for fibre and mineral content, expressed on an oven DM basis, will be over-estimated, although in most cases the error will not be large;
- ▶ Digestibility and ME content will be under-estimated;
- ▶ Protein content will be under-estimated because of volatile losses of some nitrogen compounds;
- ▶ DM intake by animals consuming silage will be under-estimated.

The microwave drying method can be used on-farm to determine the oven DM content of the parent forage or silage (see Chapter 6, Section 6.4.2). If done correctly, this oven DM can be used in conjunction with Equation 1 to estimate true DM of silages (see example at left).

12.4.2

Energy value and digestibility

The metabolisable energy system is used in Australia, i.e. the energy value of a feed is expressed as megajoules (MJ) of ME per kg of DM. The ME is that component of the feed energy available to the animal for heat production, maintenance and production (see Figure 12.6).

In balanced diets, feed intake and animal production increase with increasing ME content or digestibility of the diet (see Chapters 13 to 15). This impact on feed intake and production is the reason that 'quality' should always be the focus in any silage program.

Dietary ME content is usually the most important component when appraising feed 'quality' – and the first limiting factor in most ruminant diets. However, other 'quality' components, such as nitrogen content and fermentation quality, are also important (see Sections 12.4.4 and 12.4.5).

Few directly measured ME values are available for sheep or cattle feeds.

Measuring ME is an expensive process, using specialised equipment (a respiration chamber). More often, digestibility of the DM, organic matter (OM) or energy is determined, then prediction equations are used to estimate ME content from digestibility.

The general procedure for estimating the ME content of a feed is outlined in Figure 12.7. Note that net energy (NE) rather than ME is the feeding standard used in the United States.

It is also expensive to measure the digestibility of a feed in cattle or sheep. Various laboratory methods have been developed to estimate digestibility, allowing large numbers of samples to be routinely processed through feed testing laboratories.

In practice, the fibre content of a feed determines the extent to which it is digested (high fibre = low digestibility), which, in turn, determines its ME content. So, estimates of ME can be calculated in various ways (see Figure 12.7):

1. Digestibility is estimated from one of a number of fibre analyses that have been calibrated against samples of known digestibility – where digestibility has been determined in sheep and/or cattle. ME is then estimated from digestibility using a prediction equation derived from studies with animals where the ME was determined in a respiration chamber.
2. Digestibility is estimated using an *in vitro* digestibility procedure, based on the use of rumen fluid (obtained from sheep or cattle) or various enzymes.

Figure 12.6

Energy digestion and metabolism in ruminants.

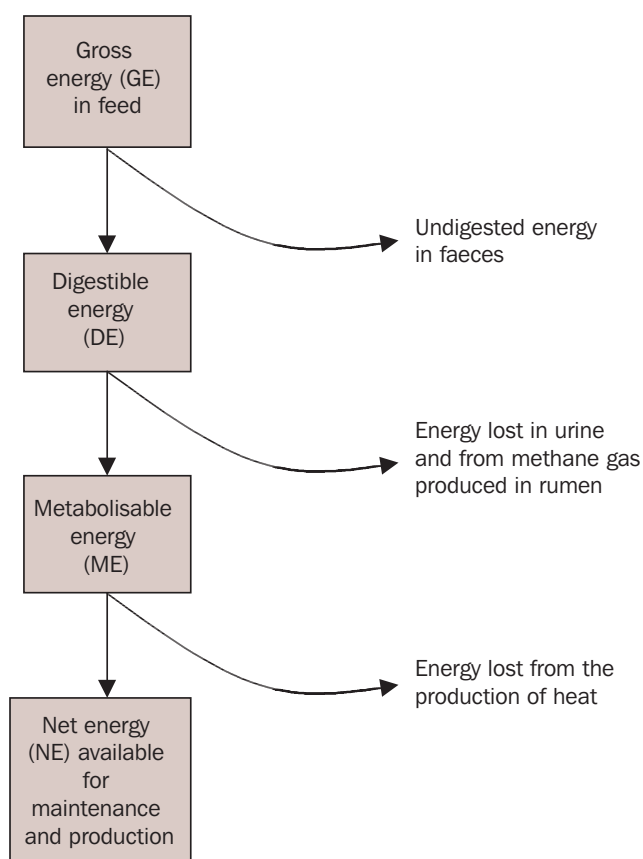

The metabolisable energy (ME) content of silages

- ME is the component of the feed energy that is available to the animal for heat production, maintenance and for production. It is measured as megajoules per kg of dry feed (MJ/kg DM).
- ME is usually the first limiting nutrient in most ruminant diets.
- It is closely related to the fibre content and digestibility of a feed, so that:
High fibre = low digestibility = low ME
Low fibre = high digestibility = high ME
(see Table 12.1).
- Feed testing laboratories calculate ME from the fibre content or the digestibility of the feed.
- ME (and digestibility) will be under-estimated if the laboratory does not take account of the volatile compounds in silage lost during oven drying.
- Potential ME values achievable from various pastures and crops are provided in Chapters 4 and 5. Producers should set silage ME targets of ≥ 10.0 for temperate forages, 10.5 for maize and > 9.5 MJ/kg DM for tropical pastures and forage crops respectively.

Plate 12.2

NIR machines are used in laboratories to simplify and speed up feed testing procedures estimating fibre components and ME.

Photograph: K. Kerr



These methods have also been calibrated against samples of known digestibility in animals. ME is then estimated from digestibility in the same way as in point 1.

3. ME can be *directly* estimated from a laboratory measure of fibre or *in vitro* digestibility, using prediction equations that have been calibrated against samples (ME standards) of known ME in animals. However, as indicated earlier, there are relatively few measures of the ME of silages in animals.

The first two are the most commonly used procedures, with the second tending to be more accurate for forages. Near Infrared Spectroscopy (NIR) is now being used extensively in feed testing laboratories to replace these slower and more expensive 'wet chemistry' methods. Various NIR calibrations are available in Australia for estimating fibre components and digestibility. NIR has been successfully used overseas to directly predict the digestibility of silages in animals. It is important that the digestibility standards used for calibration purposes include feeds that are used in Australia and are relevant to the feeds being tested.

Figure 12.7

Laboratory-based methods for estimating the energy value of feeds.

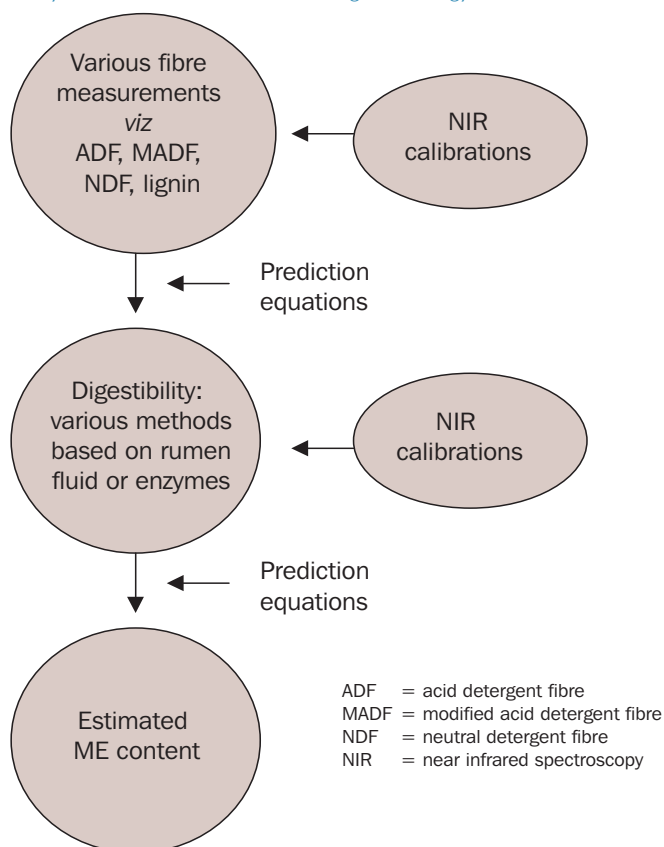

Calculating digestibility

Digestibility can be expressed in three ways – dry matter digestibility (DMD), organic matter digestibility (OMD) or digestible organic matter in the DM (DOMD). DOMD is the digestibility estimate most widely used in Europe and is sometimes referred to as the ‘D value’.

The DM of all feeds is composed of organic matter and ash. Ash content comprises the minerals present in a feed and is determined by burning a sample in a furnace at a very high temperature for several hours and measuring the weight of residue remaining.

$$\text{DM} = \text{Organic matter} + \text{ash}$$

For laboratory estimates of DM digestibility, the quantity digested is the difference between the initial sample dry weight and dry weight of residue remaining after the *in vitro* digestion process. The quantity digested is divided by the initial sample dry weight to calculate digestibility. Some laboratories determine DOMD directly, while others use prediction equations to estimate DOMD from DMD as follows:

$$\text{DOMD \%} = (0.95 \times \text{DMD \%}) - 0.9 \quad (\text{Eqn 2})$$

If ash content information is available to calculate OMD, then DOMD can be calculated without the use of this prediction equation.

Equation 2 should only be used for feeds with ash contents in the range 9-12 % of the DM. Higher ash contents may be due to soil contamination.

Some silages, such as maize silage have low ash contents (5.0 to 6.5 % ash). In this case, the above equations will underestimate DOMD %.

Alternatively, an equation developed at Wagga Wagga, NSW, from cattle digestibility studies, could be used to estimate DOMD from DMD for maize silages:

$$\text{DOMD \%} = (0.887 \times \text{DMD \%}) + 5.60 \quad (\text{Eqn 3})$$

This equation may also be appropriate for use with other low ash content silages.

Calculating ME content

Estimating the ME content of a feed involves the use of a prediction equation to estimate ME from DOMD. The following equations, which can be applied to most forages, are commonly used:

$$\text{ME (MJ/kg DM)} = (0.18 \times \text{DOMD \%}) - 1.8 \quad (\text{Eqn 4})$$

Equation 4 has been recommended by the Standing Committee on Agriculture, in Australia, and is used by some feed testing laboratories.

$$\text{ME (MJ/kg DM)} = 0.157 \times \text{DOMD \%} \quad (\text{Eqn 5})$$

Equation 5 has been more recently recommended by the Agricultural and Food Research Council (AFRC) in the UK.

Other ways to calculate digestibility

The total DM of a feed can be divided into two fractions – the organic matter (usually 85-95% of the DM) that is combusted when the feed is placed in a furnace, and the ash or residue remaining after combustion (usually 5-15%).

$$\text{Dry matter digestibility (DMD), \%} = \frac{\text{Feed DM consumed} - \text{Faeces DM}}{\text{Feed DM consumed}} \times 100$$

$$\text{Organic matter digestibility (OMD), \%} = \frac{\text{Feed OM consumed} - \text{Faeces OM}}{\text{Feed OM consumed}} \times 100$$

$$\text{Digestible organic matter in the dry matter (DOMD)*, \%} = \frac{\text{Feed OM consumed} - \text{Faeces OM}}{\text{Feed DM consumed}} \times 100$$

* Referred to as ‘D value’ in the UK.

It has the advantage of being based on direct measurements of ME in animals for a large and very diverse range of forages.

It is recommended that the following equation, which has been derived by AFRC *specifically for silages* (using DOMD corrected for volatile compounds), be used in Australia:

$$\text{ME (MJ/kg DM)} = 0.16 \times \text{DOMD \%} \quad (\text{Eqn 6})$$

Example for a silage with a 62% DOMD:

$$\begin{aligned} \text{ME (MJ/kg DM)} &= 0.16 \times 62 \\ &= 9.9 \text{ MJ/kg DM} \end{aligned}$$

Corrections for the volatile content of silages

As indicated earlier, the loss of volatile compounds during oven drying can result in the digestibility and ME content of silages being under-estimated. The volatiles lost are all organic compounds, have a high energy content and are considered to be completely digestible. In this case, DM and OM are the same (for volatile compounds). As more laboratories take volatile losses into account, the estimated ME values reported for silages have increased and are more accurate.

Correction for the loss of volatile compounds can have a significant impact on the estimated ME value for low DM silages (<30%) – the adjustment can be as great as 0.8-1.0 MJ/kg DM. However, with higher DM silages (e.g. 50%) the correction is much smaller and of the order of 0.1-0.2 MJ/kg DM.

Check if feed test results have been corrected for volatile losses. If not, seek the advice of a nutritionist.

12.4.3

Fibre analyses

In general, increased fibre content of a forage is associated with decreased digestibility and intake, and subsequently lower animal production. As a result, fibre content has been used as an indicator of feed quality and digestibility for various classes of feeds, including silage (see Figure 12.8). Table 12.1 summarises the ranges in digestibility, ME and fibre content that are likely to be seen in Australian silages.

The fibre fraction contains a range of compounds that are linked in various combinations to form the wall of individual plant cells in the forage. Individual fibre fractions can be identified using a series of chemical analyses according to the Van Soest classification system (see Figure 12.8).

Neutral Detergent Fibre (NDF)

The NDF content provides an estimate of the total cell wall content of forage. It consists of hemicellulose and the remaining fibre included in the acid detergent fibre (ADF) fraction (cellulose and lignin). Hemicellulose is partially digested by ruminants. There is evidence from some studies that feed intake in ruminants declines with increasing NDF in the forage, although results have been variable.

Acid Detergent Fibre (ADF)

The ADF fraction consists of cellulose and lignin. Cellulose is partially digested by ruminants while lignin is effectively indigestible. Lignin also forms protective barriers around the cellulose and hemicellulose components reducing their digestion. The ADF fraction also contains some unavailable (bound) nitrogen.

Digestibility of feeds declines with increasing ADF. Hence, a number of prediction equations have been developed to estimate the digestibility of forages from ADF content (often in combination with other chemical components). These are routinely used in the United States.

A modified ADF method (MADF) is often used in Europe. This method removes most of the bound nitrogen and has been reported to improve the accuracy of the relationship between fibre content and digestibility.

There is no need to measure ADF (or MADF) when *in vitro* digestibility is determined. *In vitro* digestibility is generally a more accurate predictor of the digestibility of forages in animals than ADF.

While increasing fibre content leads to a reduction in animal production, ruminants require some dietary fibre for normal rumen function (see Chapter 13, Section 13.4.2). To avoid a depression in milk fat

Table 12.1

The range of ME content, digestibility and fibre contents (NDF and ADF) seen in Australian silages.

Quality measure	Quality Range	
	Low	High
ME (MJ/kg DM)	6.7	11.3
Digestibility (DOMD), %	42	72
Neutral detergent fibre (NDF), %	72	32
Acid detergent fibre (ADF), %	47	25

content, minimum fibre requirements have been set for dairy cows:

	ADF in diet %	NDF in diet %
First 3 weeks of lactation	21	28
Peak milk production	19	25

These levels, which are based on American feeding standards from the National Research Council, can be increased as lactation progresses to avoid depression of milk fat. Seventy-five per cent (75%) of the NDF in the diet should be supplied from forages. The reader is referred to a dairy nutrition publication for a more detailed coverage of this topic.

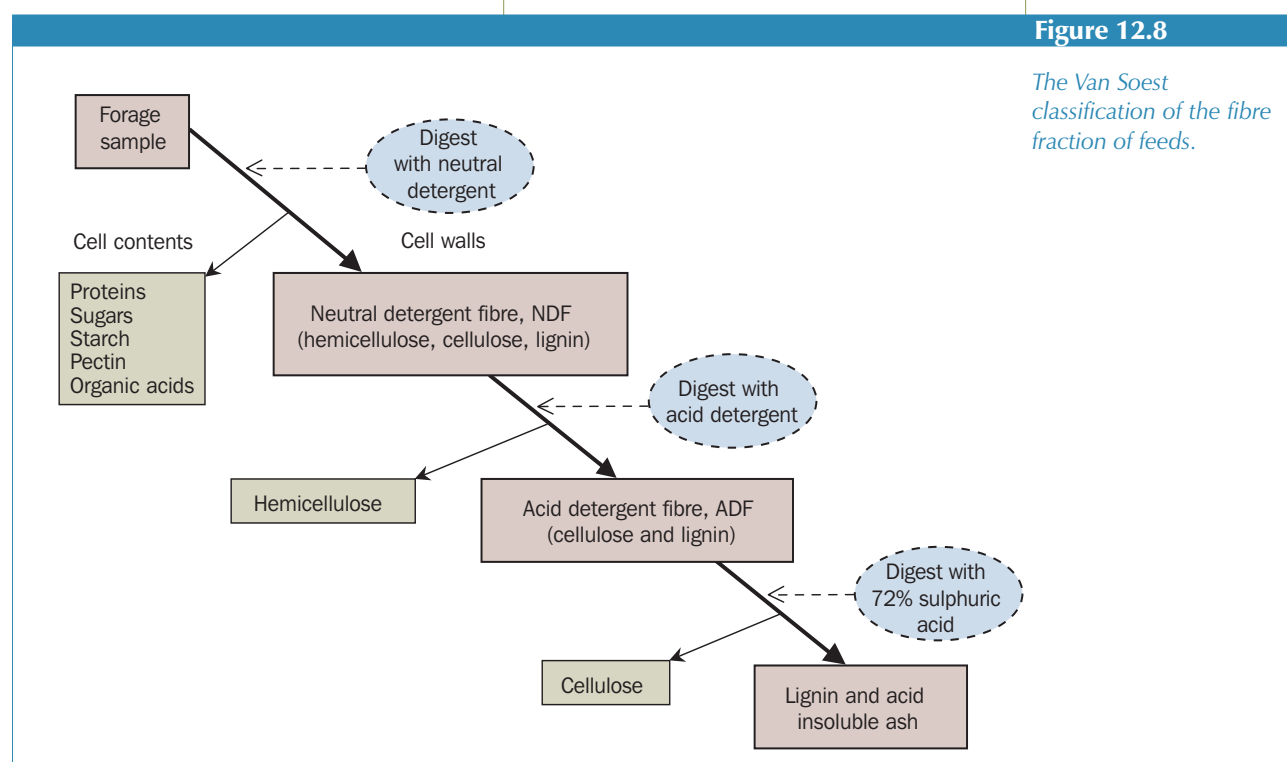
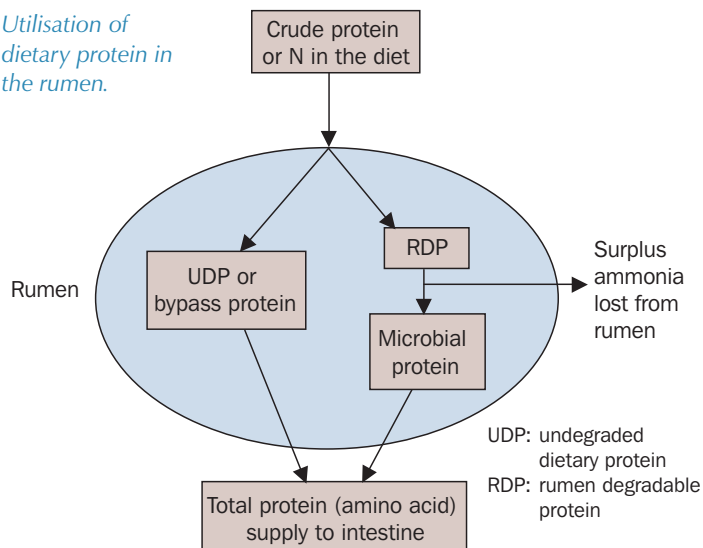

Figure 12.9

Utilisation of dietary protein in the rumen.



12.4.4

Protein analyses

Although ME, rather than protein, is usually the first limiting nutrient in forage-based diets for ruminants, inadequate protein levels can limit animal production. For sound nutritional management, it is important to know the protein content of each component of the diet. Feed testing laboratories determine the total nitrogen (N) content of silages and other feeds and estimate crude protein (CP) content by multiplying by 6.25:

$$CP \% = N \% \times 6.25$$

The total nitrogen or crude protein content of a diet does not indicate the degradability of the protein or the extent to which it is utilised by the animal.

The crude protein (CP) content of silage

- Although not usually the first limiting nutrient in most ruminant diets, inadequate crude protein (CP) levels will limit animal production.
- The protein in silage usually has a high rumen degradability.
- Some of the nitrogenous compounds in silage are volatile and are lost if the sample is oven dried, so silage CP content will be under-estimated. Check whether your feed testing laboratory conducts their silage analyses on fresh or oven dried samples.
- If it is suspected that the silage may have suffered heat damage during the ensiling process (see Chapter 2), this can be assessed by an analysis of the acid detergent insoluble nitrogen (ADIN) content of the silage.

A large proportion of the crude protein, often 90% or more for silages, is degraded in the rumen. This fraction is referred to as rumen degradable protein (RDP) (see Figure 12.9). Ruminants need adequate RDP in the diet to sustain normal microbial activity and digestive function in the rumen. How much RDP is needed is directly related to the quantity of fermentable ME supplied to the rumen by the diet.

As feed is digested in the rumen by the action of rumen microbes, the dietary RDP is utilised by the microbes and converted to microbial protein. This is subsequently digested in the intestine, and supplies a substantial component of the animal's protein requirement. A balanced supply of energy and RDP in the rumen improves the efficiency of microbial protein production. Inadequate RDP will result in a reduced rate of digestion in the rumen. A surplus (even a temporary one) of RDP, although not harmful, may result in less efficient utilisation of nitrogen with the surplus being wasted and excreted by the animal (see Figure 12.9).

The remaining proportion of dietary protein that escapes digestion in the rumen is known as undegraded dietary protein (UDP) or bypass protein. This protein, together with the microbial protein, is digested in the intestine to meet the animal's protein requirements. Production in lactating and young, rapidly growing ruminants can be limited if they have to rely almost entirely on the microbial protein produced from RDP to meet their protein requirements. In these cases protein supplements providing sources of UDP (e.g. cottonseed meal) can increase production.

Few laboratories currently provide estimates of RDP and UDP for feed samples, and nutritional advisers usually rely on 'book' values for various feed categories when formulating diets.

Effect of the loss of volatile compounds on the accuracy of crude protein analyses

As indicated earlier, the oven drying of silages will result in the loss of some of the volatile nitrogen compounds in the silage, so that nitrogen or crude protein content will be under-estimated. A study with 10 silages at NSW Agriculture’s Feed Evaluation Service in 1993 showed that the under-estimation of the true crude protein analysis varied from 0.2 to 2.2 percentage units.

Similar results were obtained in a UK study with five low DM (16-20%) ryegrass silages (see Table 12.2). In this study, volatile nitrogen losses also occurred in freeze-dried samples.

The size of the error will vary from silage to silage. It is likely to be greater when the silage protein content is high, and when silage DM content is low and the silage is poorly preserved (has a higher pH).

The under-estimation of the crude protein content of silages can be a significant problem for livestock producers who rely on feed tests to determine whether they need to buy protein supplements. The cost of purchased protein meal needed to raise the crude protein content of a silage-based diet by 1% unit is presented in the example at right.

Clearly, producers need an accurate assessment of silage crude protein content when formulating diets. This will be achieved when crude protein analyses are conducted on fresh silage samples. Producers should ask their feed testing laboratory whether the crude protein analyses reported are based on a fresh or an oven-dried sample. Research is in progress to determine if a correction equation can be developed to account for these losses.

Where analyses are based on dried samples, some allowance has to be made for the loss of nitrogen. In production feeding situations where the crude protein content of the diet appears to be borderline, and the silage comprises a significant proportion of the diet, it is recommended that producers seek nutritional advice on the need for protein supplementation.

The cost of boosting crude protein content

To calculate the cost of raising the crude protein (CP) content of a silage-based diet by 1% unit:

Silage CP content = 11% (DM basis)

Target CP content = 12% (DM basis)

Cottonseed meal CP content = 40% (DM basis)

Cottonseed meal required:

35 kg (DM basis) for each tonne of silage DM

DM content of cottonseed meal = 90%

Therefore, 39 kg cottonseed meal required (as fed basis) (35 x 100/90)

- Cottonseed meal @ \$470 /tonne
- Cost of raising CP content of each tonne silage DM by 1% unit

$$= 470 \times \frac{39}{1,000}$$

$$= \$18.33$$

Table 12.2

Silage	pH	Estimated crude protein (% DM)		
		Fresh sample	Oven dried	Freeze dried
1	4.2	14.1	12.4	13.3
2	5.4	13.5	13.5	12.4
3	3.6	14.0	13.7	13.4
4	5.6	21.4	16.5	16.4
5	5.2	19.0	12.8	11.8
Mean		16.4	13.8	13.4

Effect of sample preparation method on the estimated crude protein content (% DM) of five ryegrass silages.

Source: Based on Wilkins (1974)

Using acid detergent insoluble nitrogen (ADIN) to assess heat damage

A small proportion of the nitrogen in forages is naturally bound (in the ADF fraction) and will be unavailable to the animal. This can be measured in the laboratory as ADIN. It may also be expressed as acid detergent insoluble protein (ADIP):

$$\text{ADIP \%} = \text{ADIN \%} \times 6.25$$

When heating occurs during the ensiling or hay-making process, heat damage to the protein increases the level of bound nitrogen, and results in a significant increase in ADIN. The risk of heat damage

is greatest when forage DM >50% and compaction is poor. Heating results in a significant reduction in digestibility, particularly nitrogen digestibility, which declines markedly with increasing ADIN content (see Figure 12.10). Despite this reduction in digestibility, heated silages are often quite palatable to ruminant livestock.

The ADIN content of silage can be used as a guide to the extent of heat damage. For well-preserved silages the ADIN content is usually in the range 0.10-0.25% of DM. In the United States, the ADIN content of hays and silages is sometimes expressed as a % of total nitrogen to give an estimate of the % of nitrogen (or crude protein) that is 'bound':

% of total N (or CP) 'bound'	Heat damage
<12%	Little or none
12-15%	Some heating
>15%	Extensive heating

In the case of silages with low crude protein (e.g. maize and some cereals) the calculation of % 'bound' may give higher values, and it is unclear whether the above guidelines are appropriate for these crops.

Figure 12.10

Effect of increasing acid detergent insoluble nitrogen (ADIN) content due to heat damage on the digestibility of nitrogen (N) in lucerne silages and hays fed to sheep.

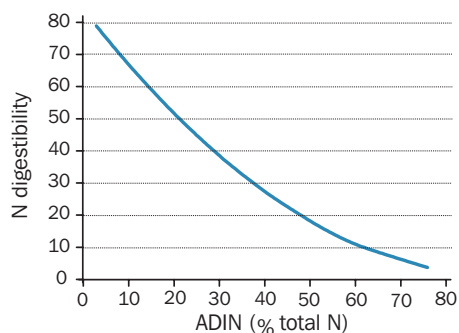

Source: Yu and Thomas (1976)

12.4.5

Silage fermentation quality

The type of silage fermentation influences the losses during fermentation and the intake of the silage by livestock (see Chapter 2, Section 2.2.2). A poor silage fermentation produces an unpalatable silage and, irrespective of its ME and crude protein content, DM intake and utilisation of silage nitrogen by the animal will be reduced.

For silage intake to be similar to that of the parent forage, the following characteristics should apply:

- ▶ ammonia-N: $\leq 5\%$ of total N;
- ▶ acetic acid: $\leq 2.5\%$ of DM; and
- ▶ other volatile fatty acids: approximately nil.

Ammonia-N is widely recognised as a key indicator of silage fermentation quality.

For a comprehensive appraisal of the fermentation quality, a full analysis of the silage fermentation products – lactic acid, volatile fatty acids, alcohols and ammonia nitrogen – will be needed. Such analyses are currently too expensive to justify their routine use in a feed testing laboratory in Australia and are usually confined to research samples. However, these more detailed analyses are available to European farmers with the use of NIR technology. Future development of the local calibrations may allow this information to become routinely available to Australian farmers. In the meantime, feed testing laboratories can provide silage pH and ammonia-N, which are useful indicators of silage fermentation quality.

Silage pH

Silage pH is a measure of silage acidity and hence the extent of the fermentation (see Chapter 2, Section 2.2.2). Silage pH is influenced by:

- ▶ DM content of the forage ensiled. As DM content increases bacterial growth is restricted and less acid is produced, so wilted silages have higher pH values.
- ▶ Sugar content of the forage ensiled. At any given DM content, silage bacteria can produce more acid if sugar content is high. Therefore, forages with a high sugar content produce silages with a lower pH.
- ▶ The type of silage fermentation. The preferred lactic acid fermentation will produce silage with a lower pH.

Silage fermentation quality

- ▶ After ME content, silage fermentation quality is probably the most important measure of silage quality influencing animal production.
- ▶ A poor silage fermentation (see Chapter 2) will result in an unpalatable silage, and even if ME and crude protein content are high, intake and animal production will be low on these silages.
- ▶ The protein fraction is extensively degraded in a poorly preserved silage, so high ammonia-N (as a % of total nitrogen) in a silage indicates a poor fermentation. Ammonia-N is an excellent guide to silage fermentation quality, with levels $\leq 10\%$ of total nitrogen indicating a good silage fermentation.
- ▶ Silage pH can also provide a guide to silage fermentation quality for silages with a DM content $\leq 35\%$.
- ▶ The risk of a poor silage fermentation can be minimised by good silage management (see Chapters 2, 6 and 7).

Table 12.3

Use of silage pH as a guide to silage fermentation quality.

Silage DM content (%)	High probability of poor fermentation if pH exceeds:	
	Grasses	Legumes*
15	4.10	4.20
20	4.20	4.30
25	4.35	4.50
30	4.50	4.70
35	4.65	4.80

* Tropical grasses with low sugar content, such as kikuyu grass, can be included in this category (see Chapter 2).

DM content should be considered when using silage pH as a guide to silage fermentation quality. When DM is low, pH values of well-preserved silages are usually in the range 3.5-4.2. Table 12.3 gives guidelines on upper limits for pH in silages of different DM contents. If silage pH exceeds these limits there is a high probability that the silage has been poorly preserved. For silages with DM contents of >35%, pH is not considered to be a useful guide to fermentation quality.

Table 12.4

Use of silage ammonia nitrogen content as a guide to silage fermentation quality.

Ammonia-N (% total silage N)	Silage fermentation quality
<5	Excellent
5-10	Good
10-15	Moderate
>15	Poor

Source: Wilkinson (1990)

Ammonia nitrogen

Ammonia-N, expressed as a percentage of the total nitrogen in the silage, is an excellent guide to silage fermentation quality. High ammonia-N is seen in poorly preserved silages and indicates extensive degradation of the forage protein during the ensiling process (see Chapter 2). Feed testing laboratories in Europe and the UK routinely provide ammonia-N values to producers.

Silage intake by ruminants declines with increasing ammonia-N content. In addition, the animals' utilisation of the silage nitrogen/protein is poor due to the rapid degradation of nitrogen in the rumen.

Table 12.4 shows how ammonia-N can be used as a guide to silage fermentation quality. In well-preserved silages, with an ammonia-N of ≤5% of total nitrogen, the intake of the silage is likely to be similar to that of the parent forage. In poorly preserved silages, ammonia-N can be as high as 50% of the total nitrogen.

While most emphasis has been placed on ammonia-N content as the most extensively degraded component of the silage N, there has been some focus on the importance of other N components in silage. It is widely accepted that, in well-preserved silages, the proportion of protein N should be high (soluble N <50% of total N). Recent research indicates that the degree of protein degradation during the ensiling process may explain the difference in animal production between apparently well-preserved silages with low ammonia-N content (see Chapter 7, Section 7.4.3; Chapter 13, Section 13.4.1; and Chapters 13 and 14). Improved liveweight gain has been observed in silages with lower levels of free amino acids. If further experiments confirm these results, free amino acids may be included in feed test analyses on silages.

12.5

Appendices

12.A1

*Composition of Australian hays and silages***Table 12A.1**

Composition (mean and range) of Australian hays and silages analysed by a feed testing laboratory over a five-year period, 1996/97 to 2000/01.

Forage type	No. of samples	Crude protein (% DM)	DM digestibility (%)	Estimated ME (MJ/kg DM)
<i>Hays</i>				
Legume	3,496	18.2 (6.1–30.7)	64.9 (39.1–79.9)	9.2 (5.0–11.7)
Legume/grass (legume dominant)	2,238	14.8 (4.1–25.4)	62.5 (39.0–77.3)	8.9 (5.2–11.2)
Grass/legume (grass dominant)	3,365	11.2 (2.9–24.5)	61.1 (45.0–77.4)	8.6 (5.7–11.2)
Grass	260	8.5 (1.4–17.7)	58.9 (45.2–69.9)	8.3 (6.2–9.9)
Cereal	4,741	7.3 (1.2–13.4)	60.0 (32.9–76.6)	8.4 (4.2–9.7)
Cereal/legume	707	10.1 (3.5–23.0)	61.6 (40.9–75.2)	8.7 (5.5–10.8)
<i>Silages</i>				
Legume	258	18.8 (6.3–27.2)	66.7 (46.1–76.3)	9.5 (5.8–11.2)
Legume/grass (legume dominant)	710	16.2 (8.6–24.7)	66.3 (42.9–77.1)	9.5 (5.9–11.1)
Grass/legume (grass dominant)	3,124	14.4 (5.2–27.3)	66.1 (39.9–80.2)	9.4 (4.8–11.6)
Grass	321	13.3 (5.2–25.1)	64.9 (48.0–76.7)	9.3 (6.7–11.1)
Cereal	467	10.3 (3.2–24.0)	62.4 (43.8–76.7)	8.8 (5.5–11.2)
Cereal/legume	189	11.8 (5.5–20.8)	62.9 (43.3–74.8)	8.9 (5.4–10.9)
Maize	531	7.8 (3.3–16.5)	69.1 (50.6–78.0)	10.5 (7.2–12.4)

Source: FEEDTEST Service, Victorian Department of Primary Industries

12.A2
Interpreting feed analysis results for problem silages
Silages 1 to 3

Test	1: Lucerne		2: Maize		3: Phalaris-dominant pasture	
	Test results	Target	Test results	Target	Test results	Target
Oven DM (% fresh)	55.0	35-50	46.0	33-38	41.2	Acceptable
True DM (% fresh)	55.7	35-50	47.2	33-38	42.7	Acceptable
Crude protein (% DM)	16.5	18-24	5.8	Acceptable	8.7	12-16
Digestibility of DM (%)	58.8	60-67	62.0	64-71	54.9	63-70
Estimated ME (MJ/kg DM)	8.8	9-10	9.7	10-11	8.2	9.5-10.5
pH	5.7	Acceptable	3.9	Acceptable	4.3	Acceptable
Ammonia-N (% total N)	9.1	Acceptable	8.5	Acceptable	8.7	Acceptable

Areas where the test results indicate silage quality is less than ideal

Preferred ranges for this silage if well managed

Interpretation:

- Silage 1.** A baled lucerne silage harvested at the late bud stage. It has been overwilted, as indicated by the high DM content, and this has resulted in increased field losses. Hence the ME and crude protein content are lower than expected.
- Silage 2.** A direct cut maize crop that has been harvested with a forage harvester, at a milk line score (MLS) of 4. The high DM content indicates that this maize crop has been harvested too late. ME content is low because of the late harvest. Difficulty in compacting the drier forage could also have led to higher in-silo losses and a further reduction in ME. (Note: Compared to other silages here, a different calculation method has been used to estimate the ME content of maize silage from DM digestibility.)
- Silage 3.** A baled phalaris silage cut when in head. This pasture has been cut too late and as a result both ME and crude protein are low.

Silages 4 to 6

Test	4 – Clover dominant pasture		5 – Ryegrass/white clover		6 – Kikuyu grass	
	Test results	Target	Test results	Target	Test results	Target
Oven DM (% fresh)	19.0	35-40	22.0	30-40	28.0	35-40
True DM (% fresh)	21.8	35-40	24.6	30-40	30.3	35-40
Crude protein (% DM)	17.2	Acceptable	16.5	Acceptable	16.2	Acceptable
Digestibility of DM (%)	72.7	Acceptable	74.6	Acceptable	64.8	Acceptable
Estimated ME (MJ/kg DM)	10.9	Acceptable	11.2	Acceptable	9.7	Acceptable
pH	5.2	<4.3	4.0	Acceptable	5.2	<4.5
Ammonia-N (% total N)	18.2	<10	9.2	Acceptable	22.3	<10

Areas where the test results indicate silage quality is less than ideal

Preferred ranges for this silage if well managed

Interpretation:

- Silage 4.** Clover silage harvested with a precision chop forage harvester in early spring. This silage has not been adequately wilted, as indicated by the low DM level. This has resulted in poor fermentation quality, as indicated by the high ammonia-N and pH (see Table 12.3). Effluent losses would be high from this silage.
- Silage 5.** A ryegrass/white clover silage harvested before ear emergence in the ryegrass, using a precision chop forage harvester. Although this precision chopped silage has not been adequately wilted, the silage fermentation quality has not suffered. However, there would be significant effluent losses.
- Silage 6.** This precision chopped kikuyu silage was produced from 28-day regrowth pasture. The kikuyu was wilted slowly over two days under difficult wilting conditions. The ME and crude protein contents are within the normal range for kikuyu grass cut at the correct stage of growth. However, the DM content is lower than the target of 35%. Silage fermentation quality has suffered (high ammonia-N and pH) as a result of the slow rate of wilt.